



HF ALKYLATION CORROSION ASSESSMENT LEARNINGS

Agenda

? Introduction to OLI

🧪 Importance of HF Alkylation Corrosion Modeling

✓ Case Studies













📊 Key Learnings

💻 Conclusion and Q/A

Introduction to OLI Systems

- Established in 1971, headquarters in New Jersey, USA
 - EMEA office established in London, UK 2019
- Pioneered the understanding and application of water chemistry science to real world industrial challenges
- First principles based physical property modelling
- Innovation in water chemistry properties, thermodynamic models and software tools
 - Combination of chemistry, process flowsheets, scaling & corrosion calculations
- 500+ clients
- OLI Electrolyte property database
 - Aspentech, AVEVA, Honeywell, KBC, PSE, SysCad, Schlumberger

OLI Products

Industries	 Oil & Gas	 Chemicals	 Metals & Mining	 Lithium & REE Recovery	 Power Generation	 Water Treatment	 Academia	 Research/ Government
Computation	 OLI Engine Performs calculations that accurately predict the behavior of complex and concentrated electrolyte systems, using real solution theory				 Chemistry Database Speciation of over 80+ elements covering a broad range of industry applications			
Desktop Software	 <ul style="list-style-type: none"> • Stream Analyzer • Corrosion Analyzer • ScaleChem 			 <ul style="list-style-type: none"> • Flowsheet: ESP 		 <ul style="list-style-type: none"> • OLI Alliance Engine* 		

*OLI Alliance Engine

OLI Engine in Aspen Plus	OLI Engine in gPROMS
OLI Engine in Aspen Hysys	OLI Engine in IDEAS
OLI Engine in SysCAD	OLI Engine in Symmetry
OLI Engine in METSIM	OLI Engine in Proll
OLI Engine in UniSim Design	OLI Engine in KBC Petro-SIM

Holistic approach to corrosion modeling and support

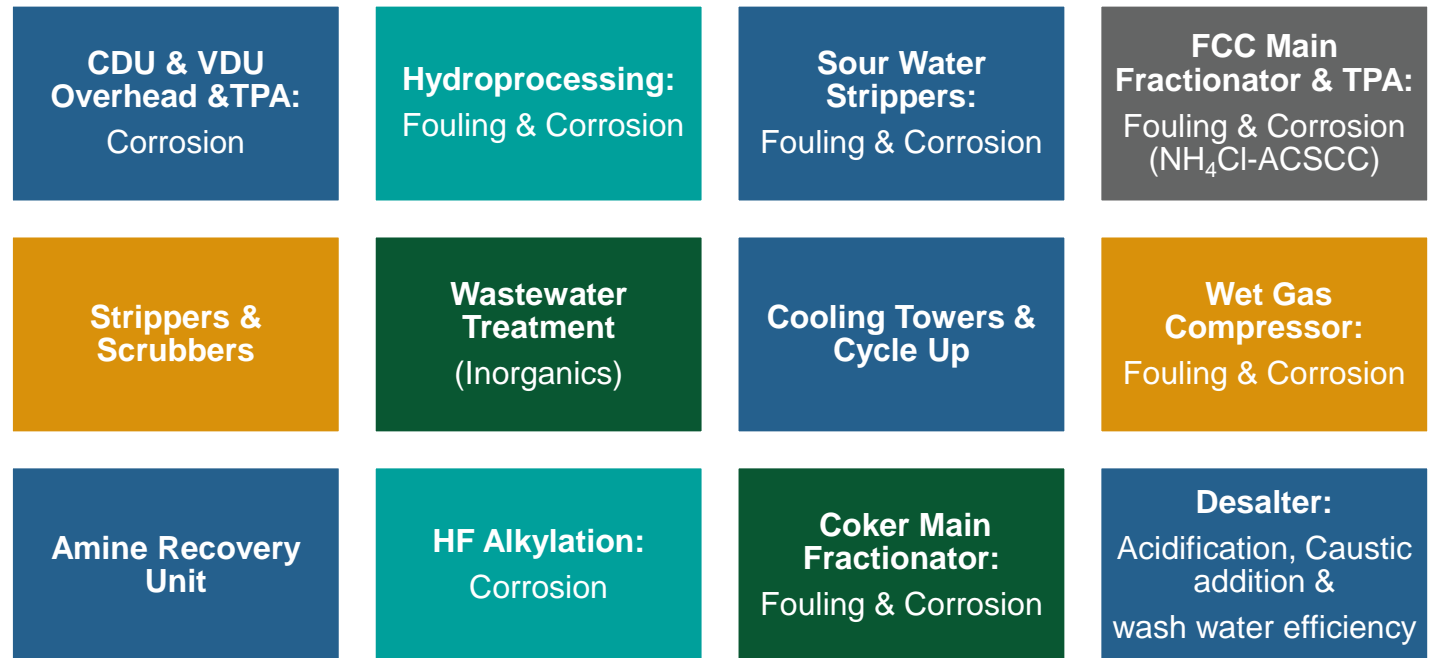
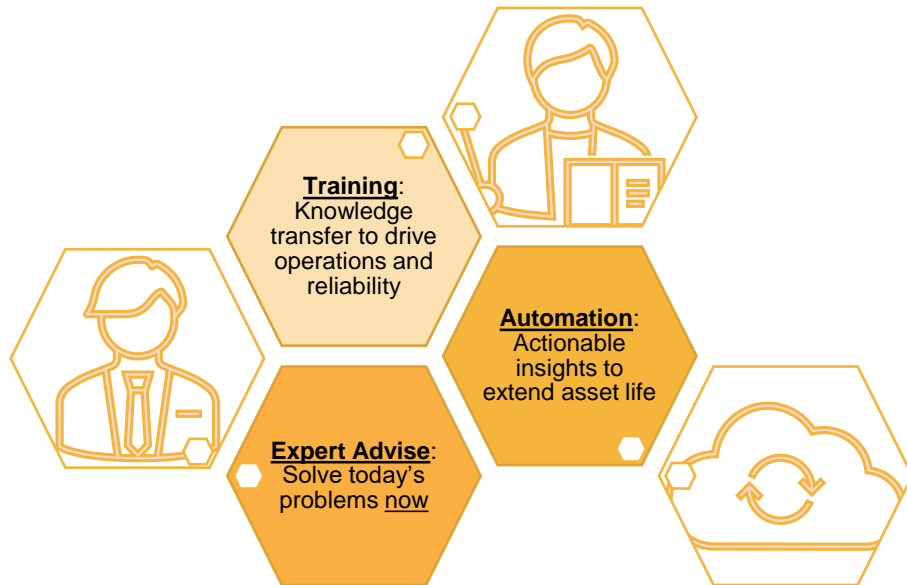

Importance of HF Alkylation Modeling

- Preventing Catastrophic Failures

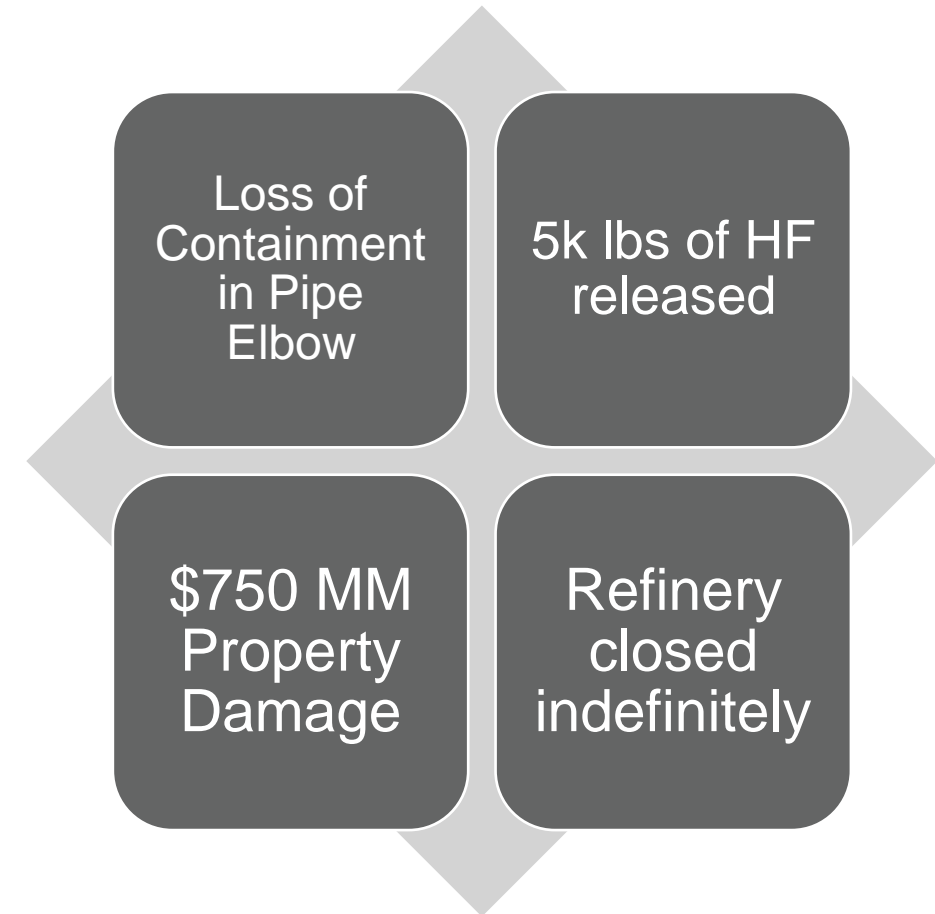

OLI Validation Plots increase confidence

Solubility of HF in Isobutane

Symbols are experimental points
Curves are OLI predictions

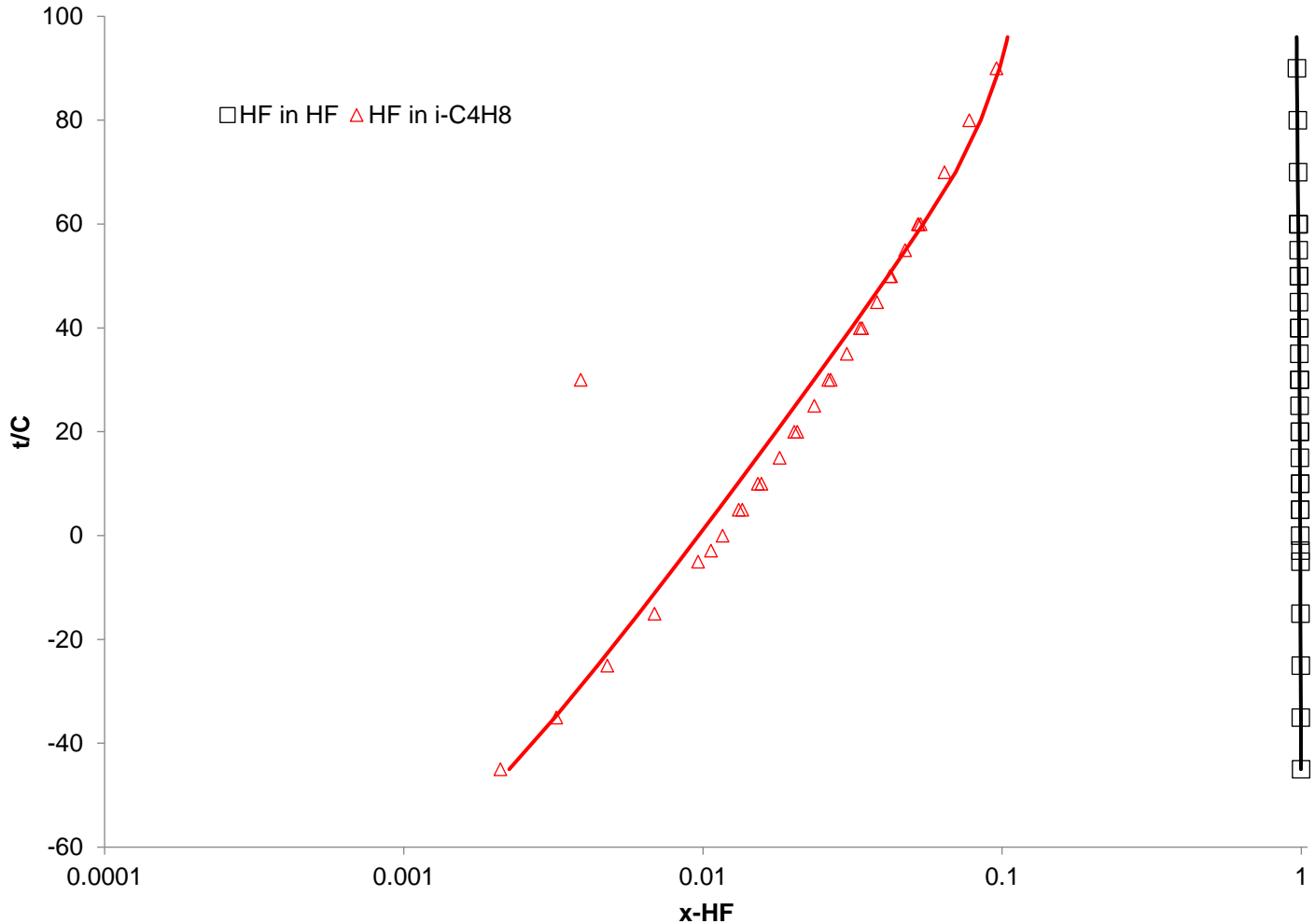

OLI Validation Plots increase confidence

Solubility of HF & H2O In Hydrocarbons

Symbols are experimental points
Curves are OLI predictions

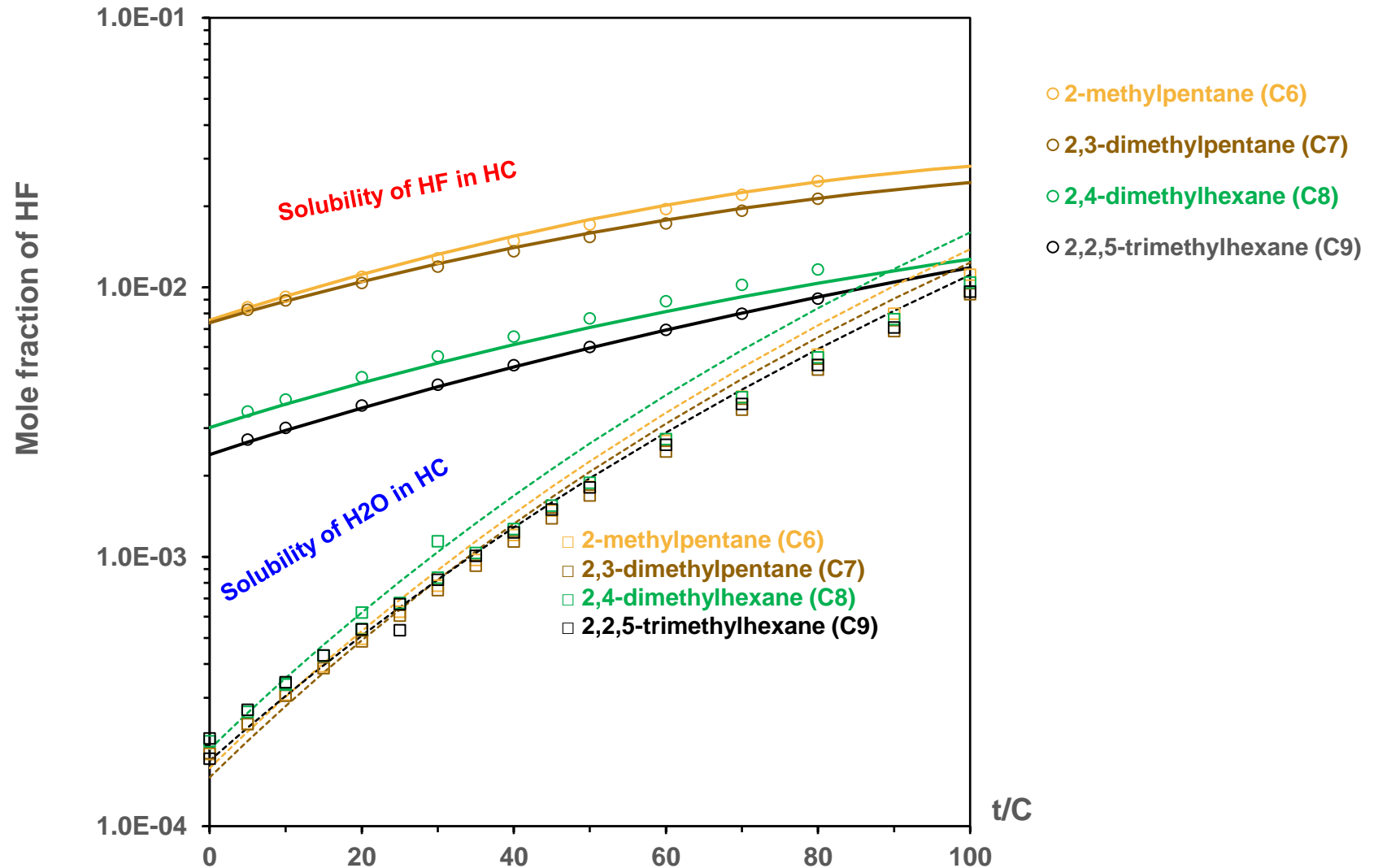

Phase Equilibria in HF Alkylation Process:

Settler Outlet Heated Through Feed/iC4 Exchangers

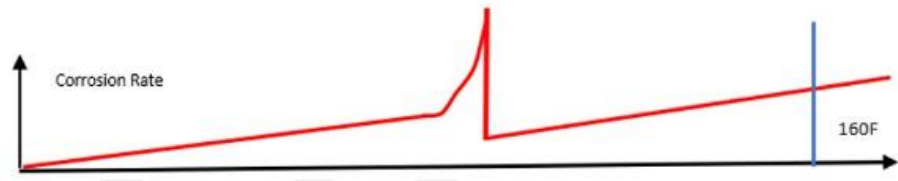
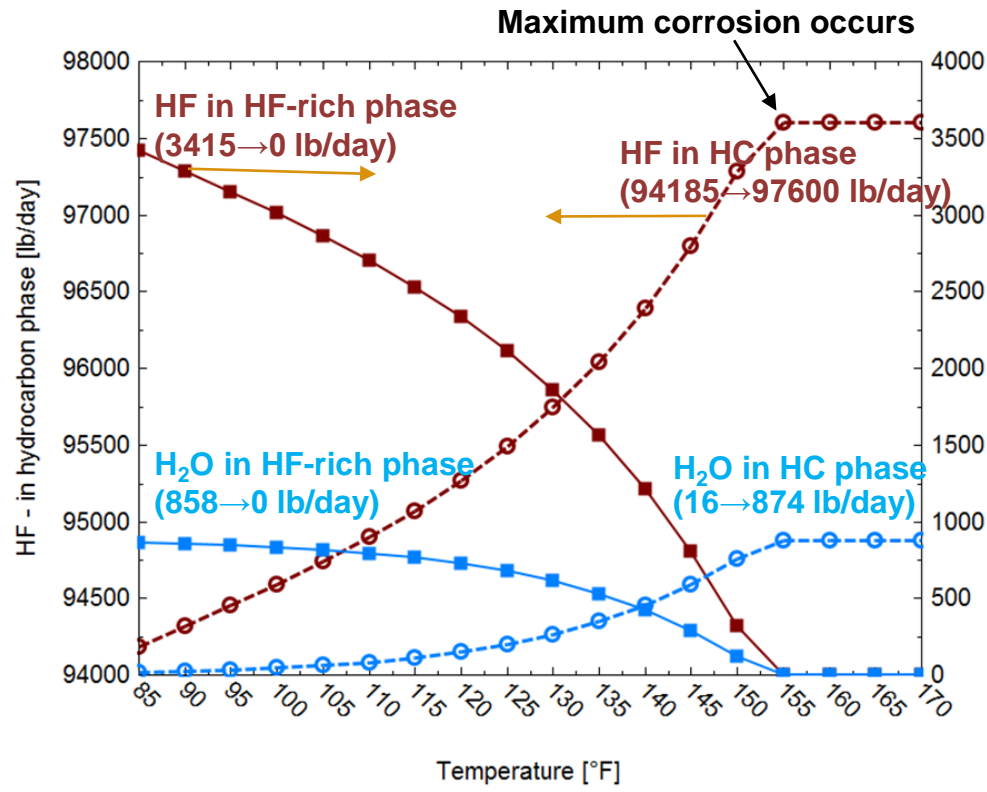

Why corrosion increases – driving force for corrosivity

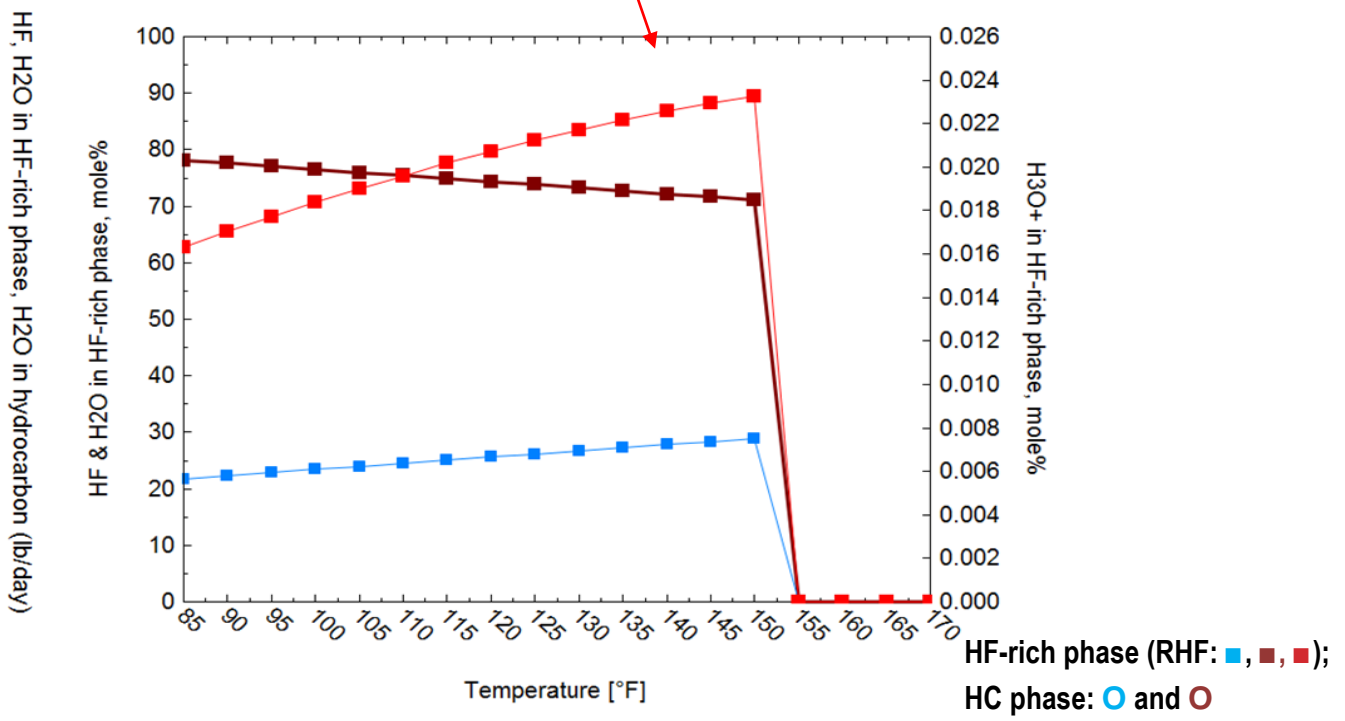



Modeling Corrosion and Learning from Experience: Enhancing HF Alkylation Unit Reliability

Known Problem Areas of the Fractionation Section

Fractionation (entrained RHF)

- IsoStripper/DIB
- Depropanizer
- HF Stripper

Services

- Feed preheating
- Tower – flash zone or reflux
- OVHD – condensing

Problems

- Localized Corrosion
- Piping systems including dead-legs
- Tower (feed inlets, reflux returns)
- In some cases, rcy-iC4 lines

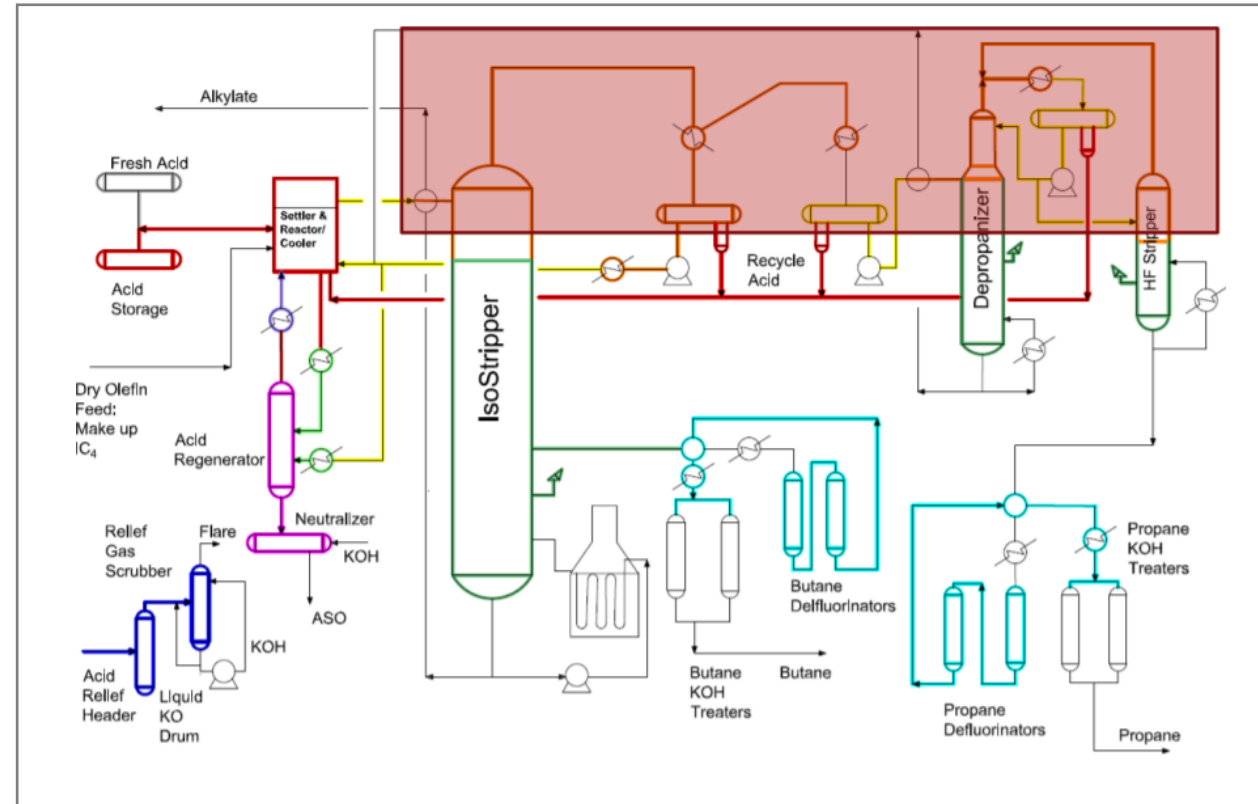



Case Studies

Case 1: Main Fractionator Feed Line Corrosion

Understand corrosion through acid balance

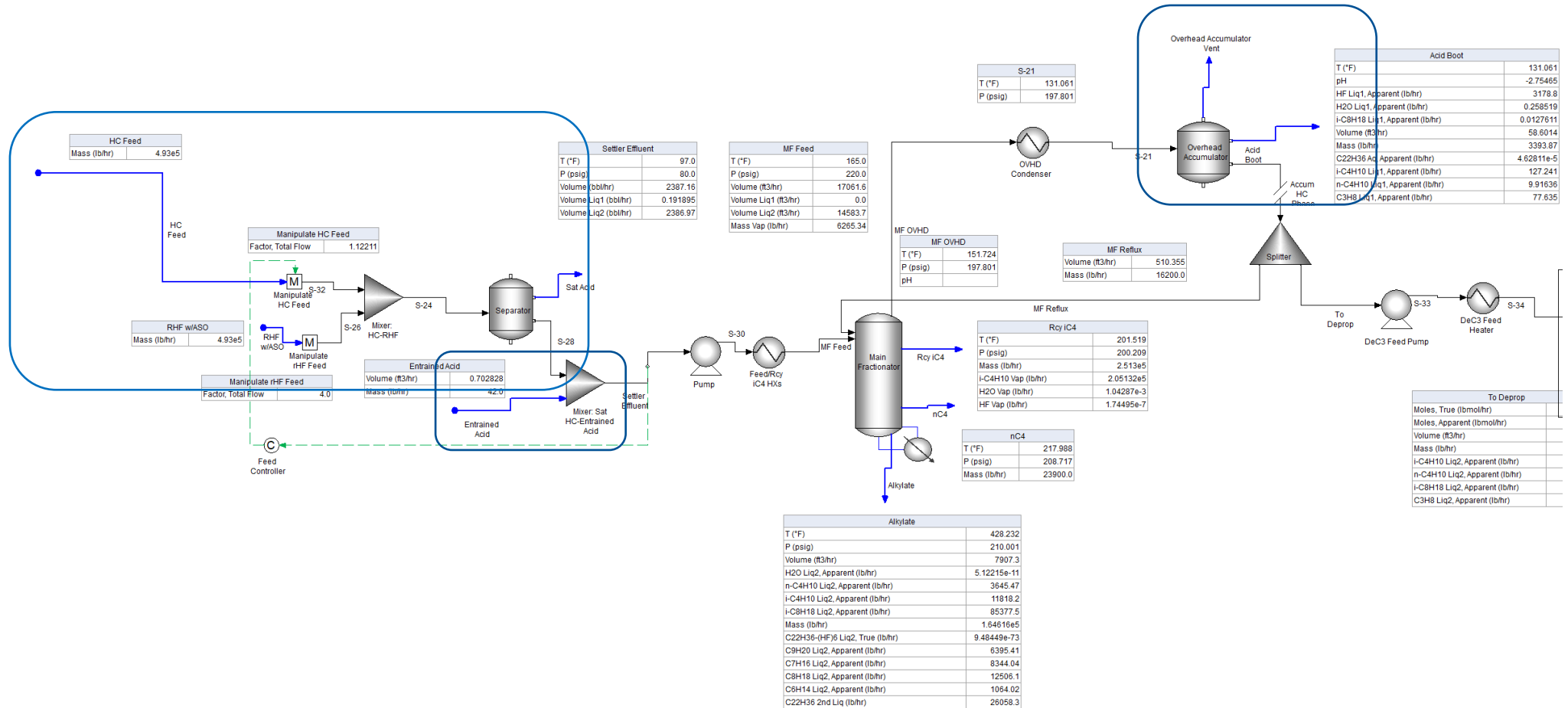

Case 1: Main Fractionator Feed Line Corrosion

Understand corrosion through acid balance

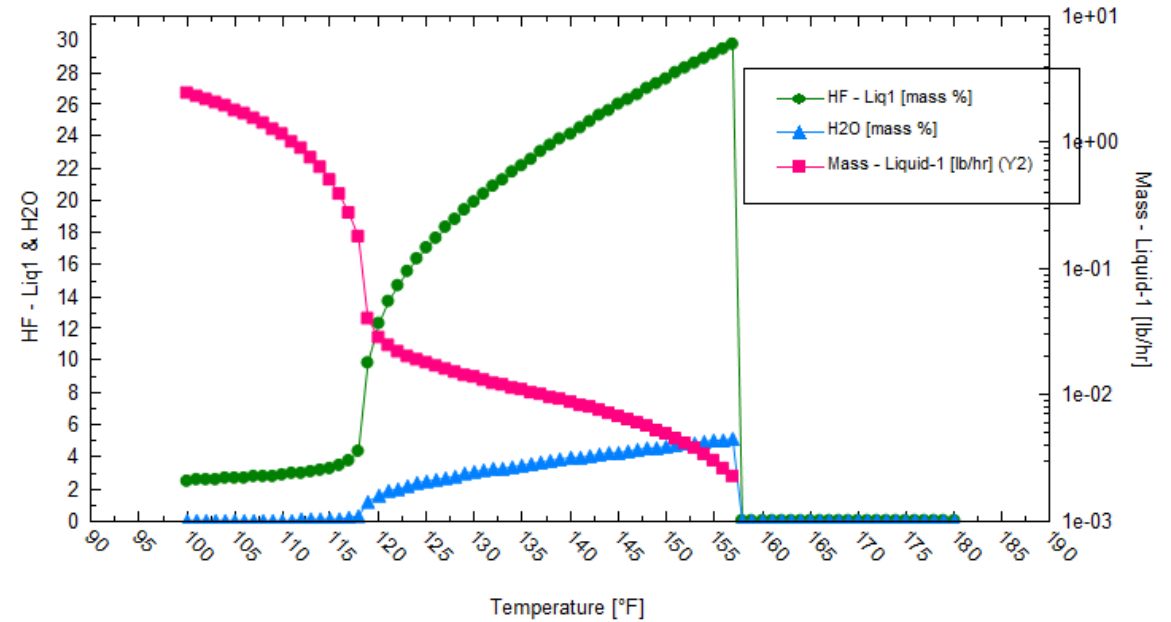
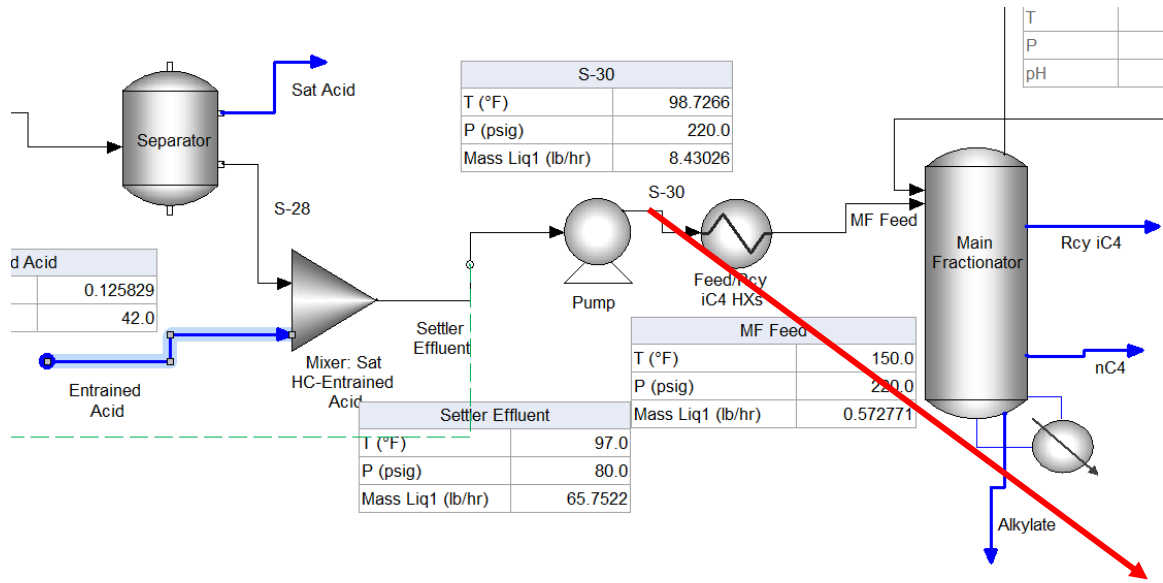

Case 1: Main Fractionator Feed Line Corrosion

Understand corrosion through acid balance

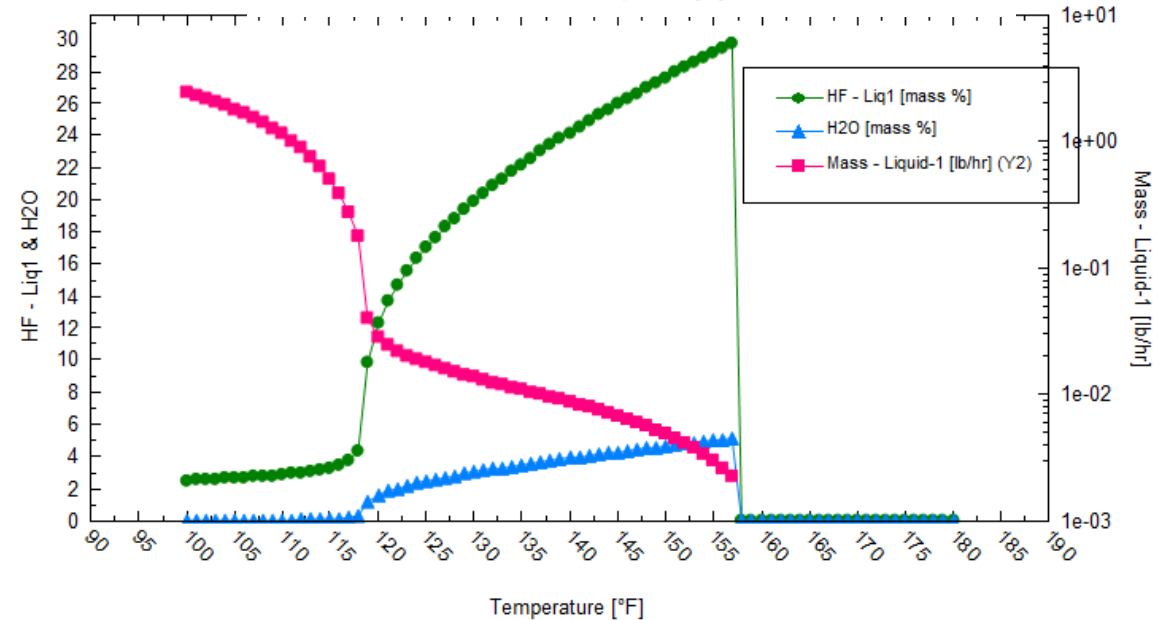
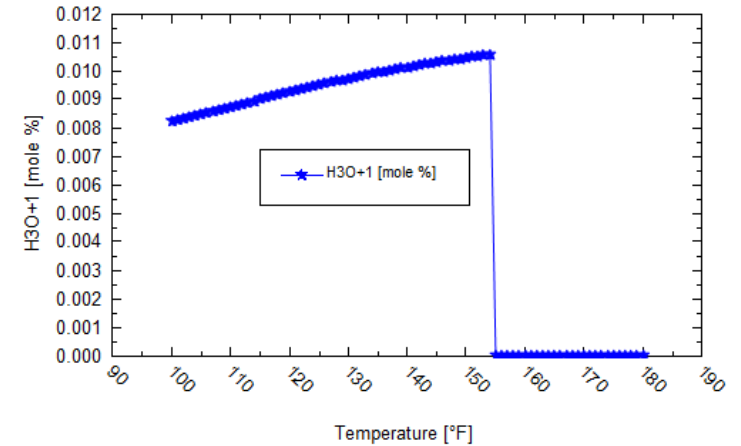
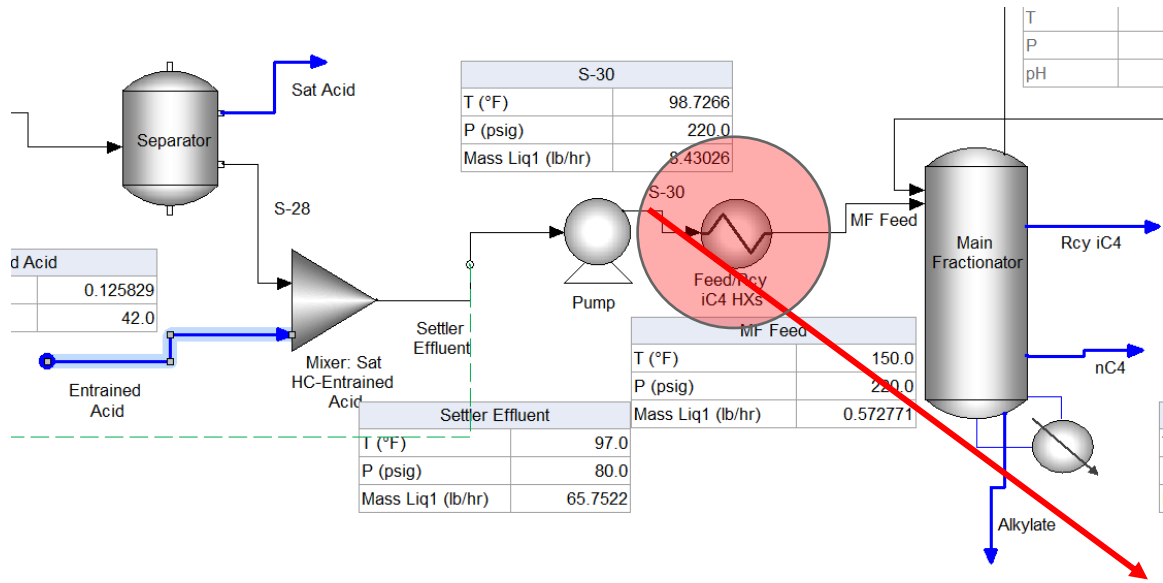

Transition Temperature Graph for a High Entrainment Unit

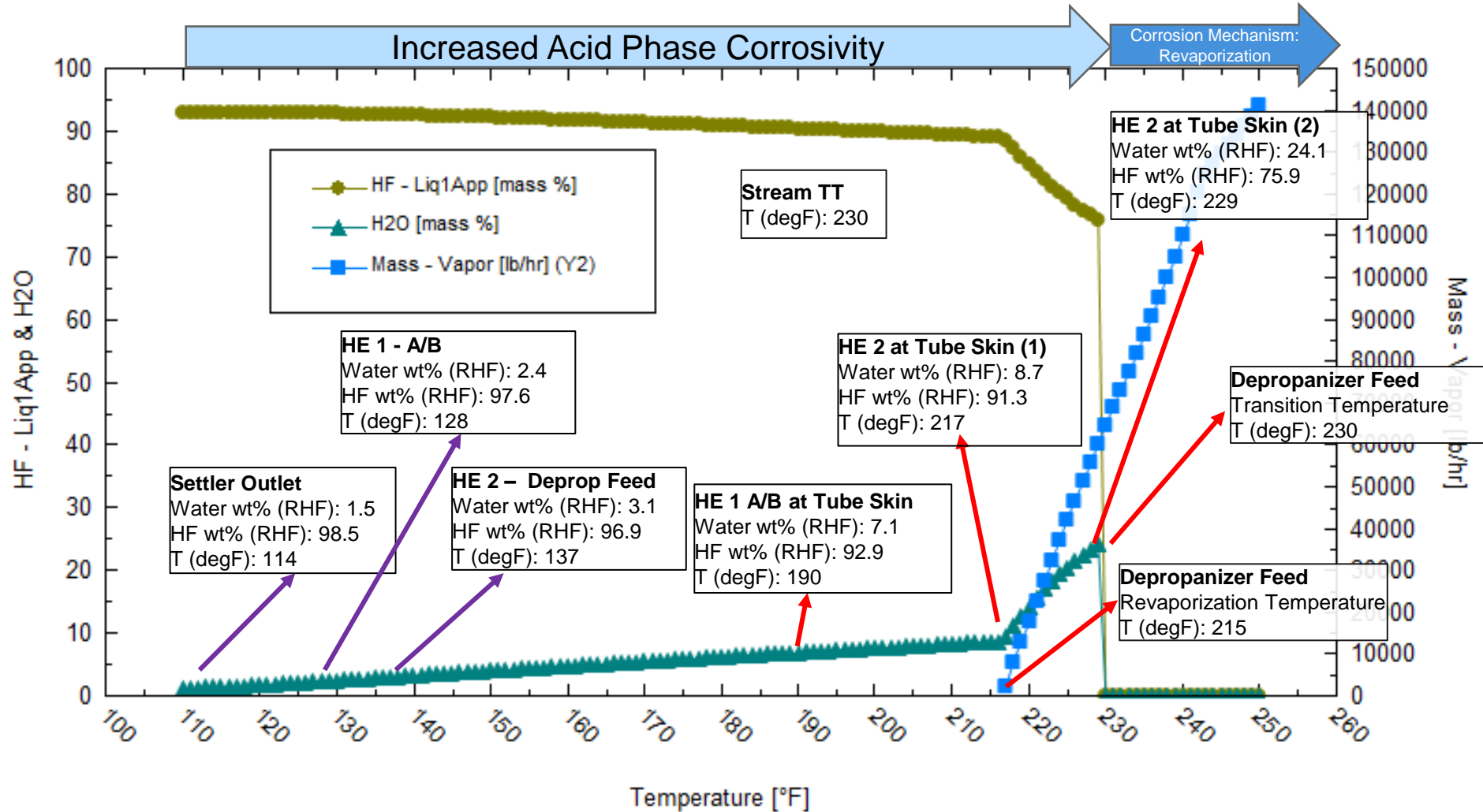

Difference Between Bulk and Skin T Operating Envelopes

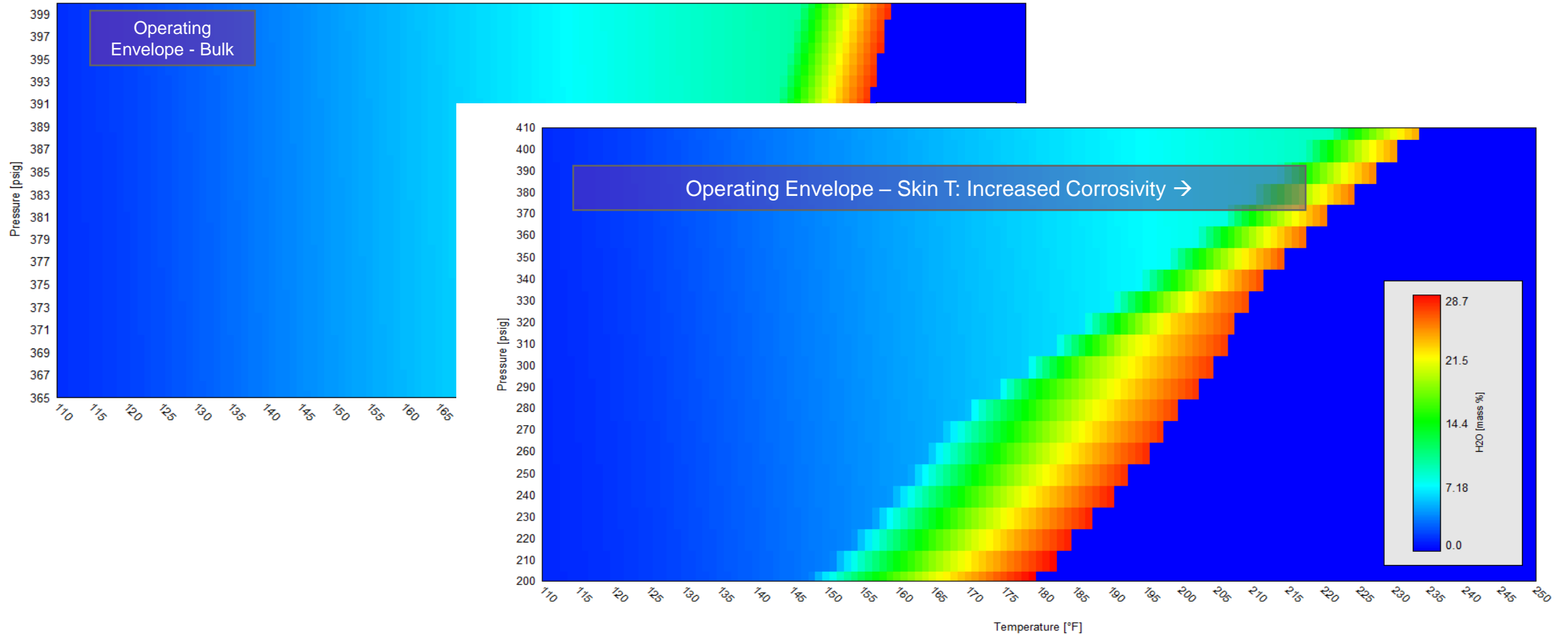

Fractionation Train Overhead – Analyze all streams for Risk

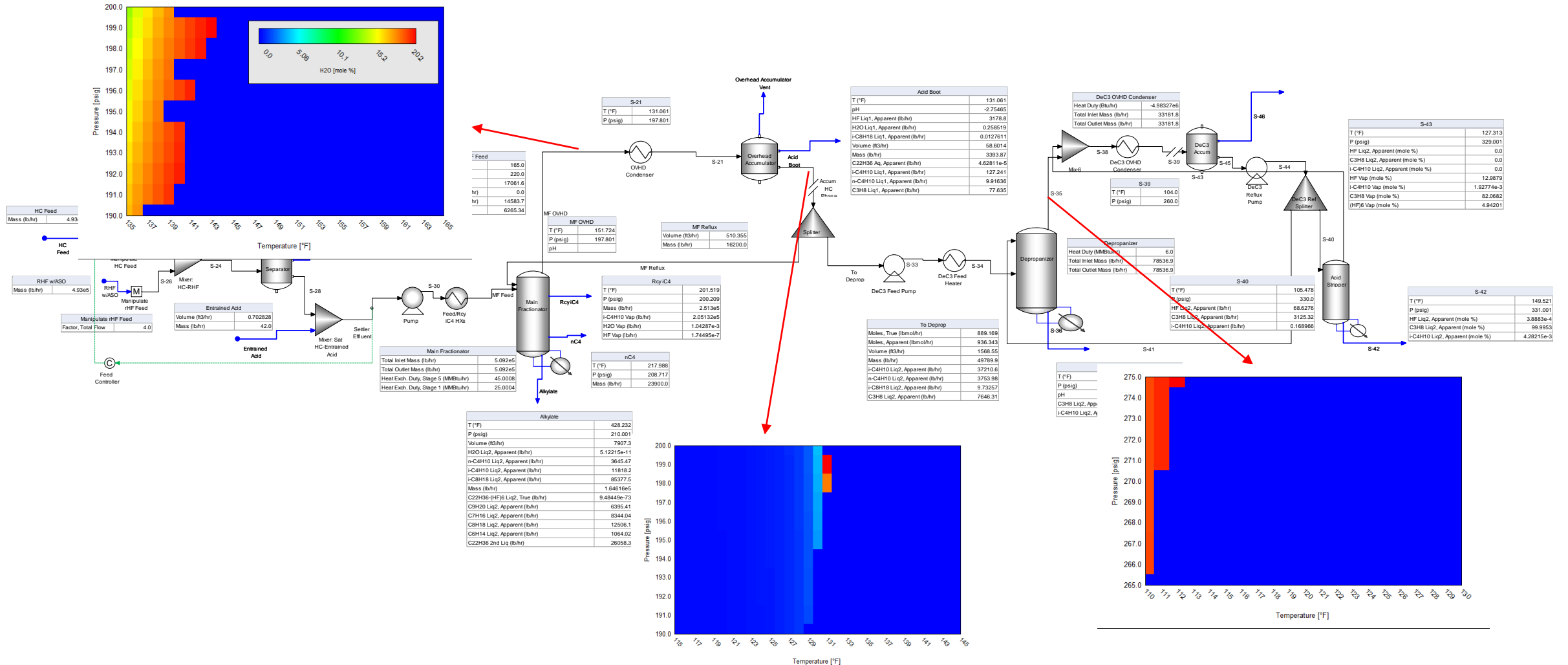

Case 2: Feed/Rcy i-C4 Heat Exchangers

Corrosion Assessment Summary

Stream: Settler outlet to Main Fractionator Feed against known corrosion rates for HF/Water solutions

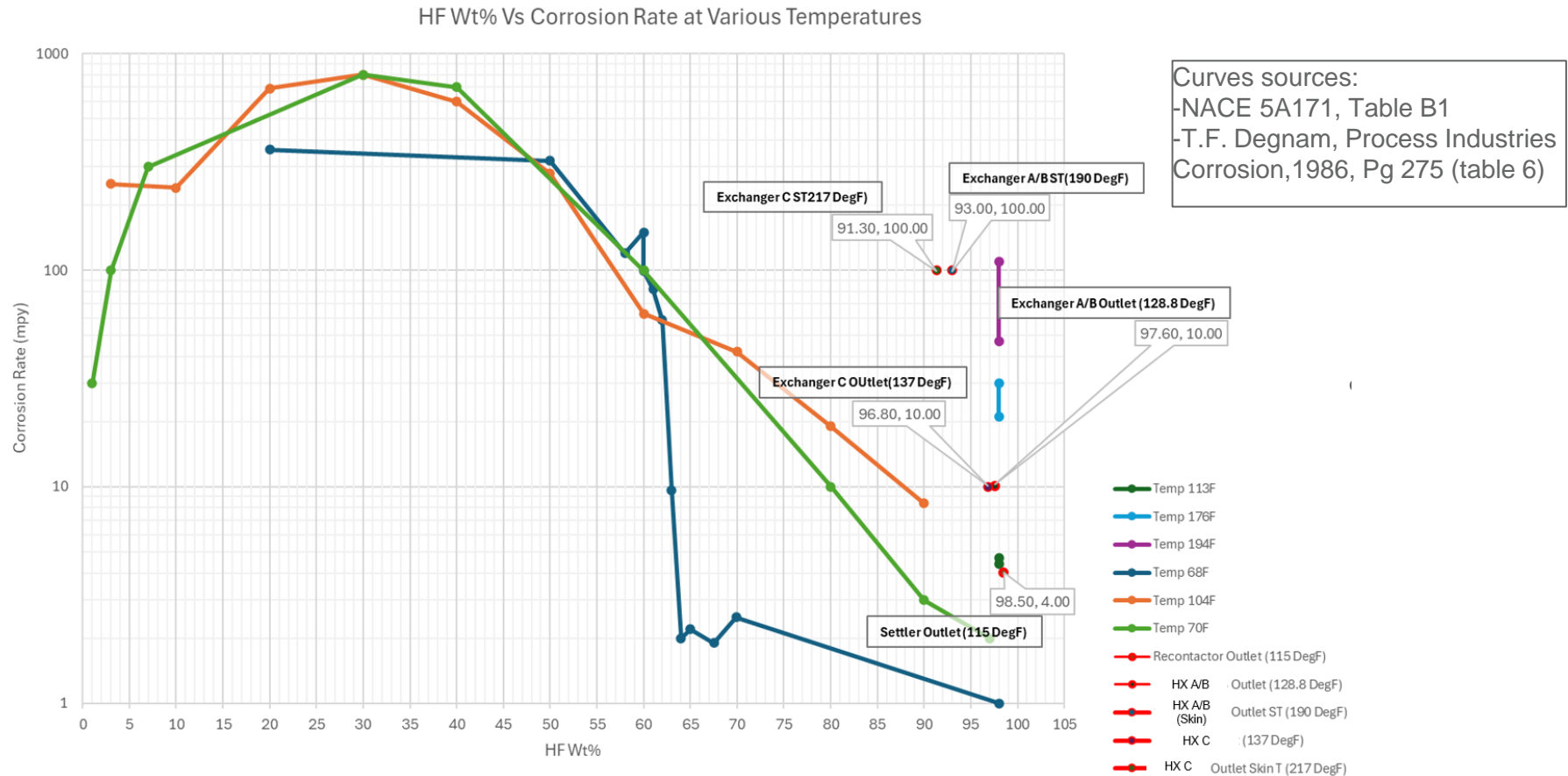

Case : Corrosion Inside the Tower – Diagram (TBD)

- Flash Zone corrosion can be present in Depropanizers and Isostrippers
- Highly dependent on amount of entrainment coming into the tower
- Separate Acid Phase should form above flash zone
- Increased entrainment pushes Acid Phase below, creating high water to HF ratios
 - As high as 72 mol% water, 28 mol% HF

Stage #	HF mol% In Acid Phase	Water mol% In Acid Phase	Acid Phase Flow Rate (lb/hr)
Column Inlet 18	54.1722	45.7506	4301.32
17	40.6965	59.2049	4023.6
16	34.4188	65.4726	3820.31
15	31.2143	68.6723	3711.38
14	29.4849	70.3995	3601.63
13	28.5095	71.3739	3336.57
12	27.9203	71.9625	2476.12
11	0.0142069	0.657061	6.98297e5
10	5.26784e-4	0.274808	7.2046e5
9	1.83524e-5	0.11131	7.29782e5
8	6.22764e-7	0.0445645	7.3574e5
7	2.08352e-8	0.0177414	7.40455e5
6	6.90262e-10	7.0378e-3	7.44772e5

Acid Phase Dissolved/Vaporized

Case 1: Corrosion Inside the Tower

Perform Heat Duty Studies on Columns to Avoid Flash Zone Corrosion

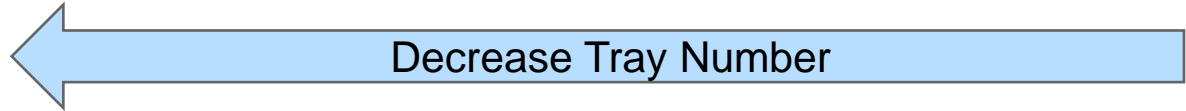

Base Case Acid Liquid Phase Per Tray - Base (grey), Medium (yellow), High (blue)

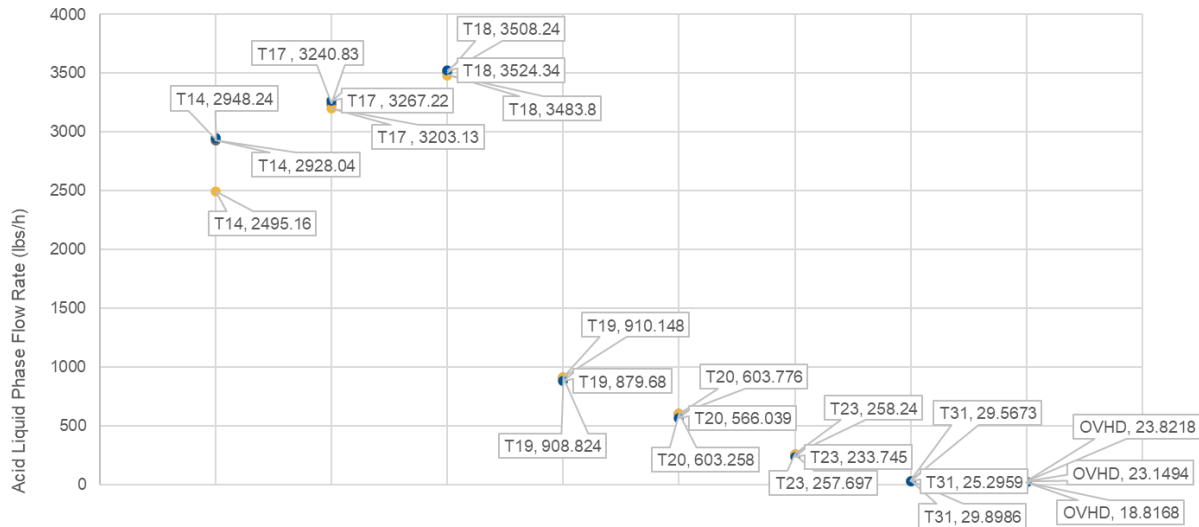

Base Case Vs 4% Additional Duty - Tray Temperatures

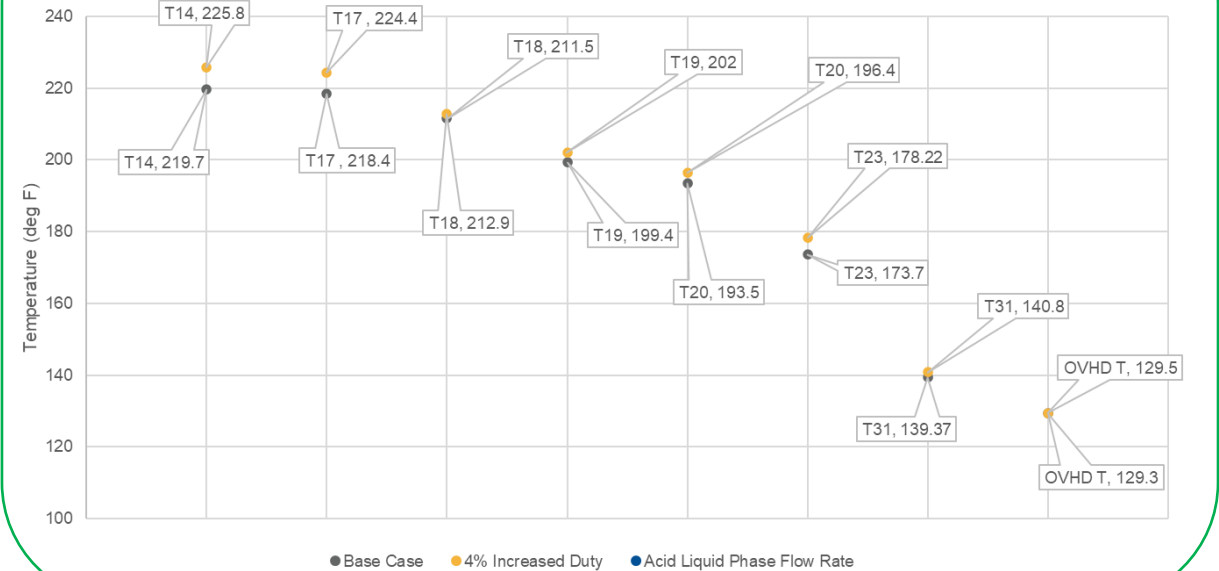

Lessons Learned

- Acid balance is crucial for calculating acid entrainment
 - Recommended: Acid boot flow meter – most accurate
 - Fill tests – prone to error
 - Matching corrosion observed to levels of entrainment – last resort
- Increased Entrainment can be due to multiple factors – modeling ideal to help set IOWs
 - Perform unit changes and check against acid balance

Date	Unit Feed Rate (klbs/d)	Water in RHF (wt%)	Settler Level	Settler Eff. T	Settler Effluent SG	Settler Flux (GPM/Ft2)	Acid Boot Fill Rate (BPH)	Dissolved Acid (lb/h)	Entrained Acid (lb/h)	Main Frac. Inlet T (F)	Transition Temperature (F)
1-Oct	450	1.6	58	102	0.569	14.7	11.5	4900	60	160	152
2-Oct	430	1.2	75	102	0.568	14.7	11.4	4875	55	160	151
3-Oct	420	1.6	50	97	0.568	15.3	10.7	4505	41	155	147
4-Oct	480	1.8	65	120	0.562	14.6	12.1	5505	110	167	170
5-Oct	455	1.3	74	105	0.563	14.3	11.8	5102	87	162	160
6-Oct	462	1.5	55	109	0.563	13.9	11.9	5003	79	163	164

- Increased entrainment not only affects feed and overhead lines, column also affected
 - Modeling can be used to identify operating P, Reflux, Tower Heat Duy, etc. to avoid an acid phase below the flash zone
 - Setup IOWs around tower operations
- Important: Acid balance to include depropanizer, HF Stripper – helps to calculate entrainment from those OVHD accumulators.

www.olisystems.com

